

Instruction for air bleeding of hydraulic damping system

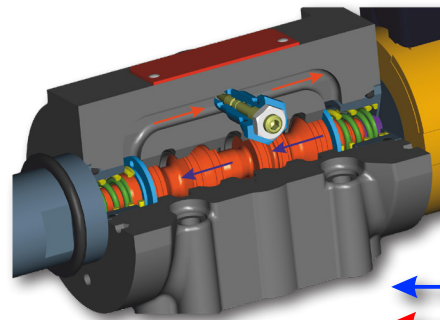
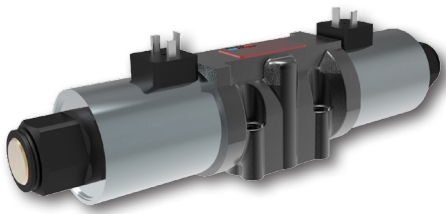

← Spool movement
← Fluid flow

T0 - Plug VSTI M10x1	T2 - Nozzle $\varnothing 0.6$ (0.02)	T3 - Adjustable needle restrictor
For closing of machined threaded hole	Shifting time extension: 120 – 350 ms	Shifting time extension: 30 – 2000 ms

The shifting time is valid at fluid kinematic viscosity $\nu = 32 \text{ mms}^{-2}$ and nominal voltage supply.
The shifting time depends on translated hydraulic power (product of pressure and volumetric flow).

The hydraulic damping is used for slower smooth movement of spool and pressure picks elimination. The damping is realized by throttling of fluid flowing through the connecting channel during the spool moving with built-in nozzle or adjustable needle flow restrictor (simple throttle valve). For reliable function the damping system must be de-aerated.

WARNING



Do not bleed the damping system at higher pressure in T-channel. There is a risk of working fluid external leakage.

Loosen the nozzle / restrictor with a wrench 14. At pressure in T-channel, approx. 10 bar, switch alternately and repeatedly control solenoids of the directional control valve until the fluid starts to flow out through the thread. Then tighten the nozzle / restrictor to the specified torque of 10 Nm.

