

3-Way Pressure Compensator, Spool-Type, Direct-Acting

TV2-103/S

M27x2 • Q_{max} 80 l/min (21 GPM) • p_{max} 350 bar (5100 PSI)

TV2-103/S*C

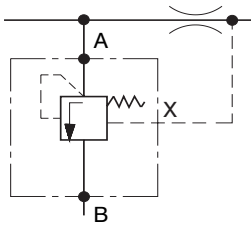

TV2-103/S*S (RP)

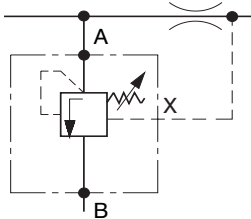

TV2-103/S*C

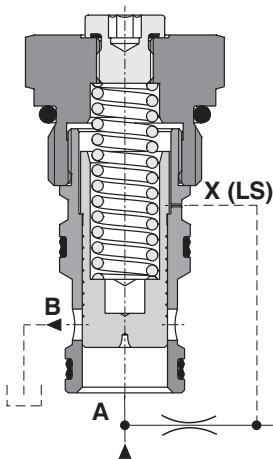

Technical Features

- › The valve keeps the pressure drop between the inlet and the pilot connection at a constant level
- › Used as a load sensing valve with proportional directional and flow valves to control the flow rate independently of pressure variations
- › Excellent stability throughout flow range with rapid response to dynamic pressure changes
- › Spring setting of the variable adjustment compensator can be varied from 4 to 14 bar (58 to 203 PSI)
- › Quiet and modulate response to load changes
- › Integrated stroke limiter for reliable operation
- › Adjustable by allen key or hand knob, or delivered with fix setting
- › Hardened precision parts
- › High flow capacity
- › In the standard version, the valve is zinc-coated for 240 h protection acc. to ISO 9227

Functional Description

A normally closed, direct-acting, spring loaded pressure compensator valve in the form of a screw-in cartridge.

From the outlet of the controlled directional or proportional flow valve a load sensing signal is taken to the spring chamber of the pressure compensator port X.

Typically, 3-way pressure compensators are used as meter-in regulators in parallel with flow restrictor valves when raising or lowering variable loads at the same velocity is required.

The pressure compensator valve then keeps the pressure difference between its pressure inlet and the pressure at the output port of the regulated flow valve nearly constant.

When the pressure differential exceeds the pre-set value, the pressure compensator opens and releases excessive flow from the main circuit to port B. If there is no flow demand from the consumer, the compensator allows the oil to flow back to tank and therefore vents the whole system. This prevents the hydraulic system from overheating especially in load sensing circuits with a fixed displacement pump.

Technical Data

Valve size / Cartridge cavity	M27x2 / QM3	
Max. operating pressure	bar (PSI)	350 (5080)
Max. flow	l/min (GPM)	80 (21.1)
Control pressure differential	bar (PSI)	4 ... 14 (58 ... 203)
Fluid temperature range (NBR)	°C (°F)	-30 ... +100 (-22 ... +212)
Fluid temperature range (FPM)	°C (°F)	-20 ... +120 (-4 ... +248)
Mass	kg (lbs)	0.15 (0.3)

	Data Sheet	Type
General information	GI_0060	Products and operating conditions
Valve bodies	Sandwich mounted	SB-04(06)_0028
Cavity details	SMT_0019	SMT-QM3*
Spare parts	SP_8010	

Characteristics measured at $v = 32 \text{ mm}^2/\text{s}$ (156 SUS)

Regulated flow related to input pressure

The characteristic of the pressure compensator corresponds with the flow rate of a PRM2-103Z11/60 proportional directional valve.

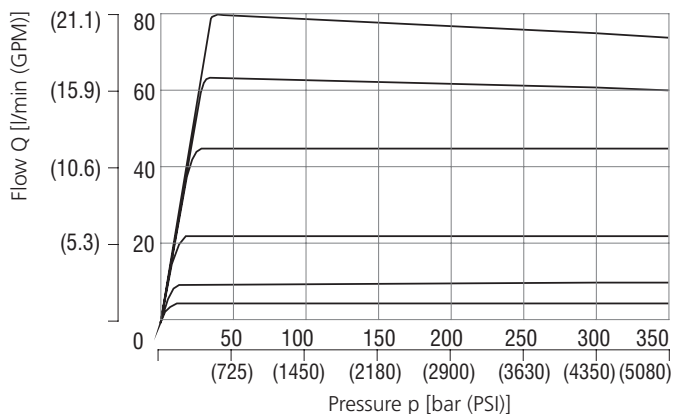

If the pressure resistance increases due to a flow rate increase, the pressure differential also has to increase in order to ensure correct regulation.

Dimensions in millimeters (inches)

TV2-103/S*C

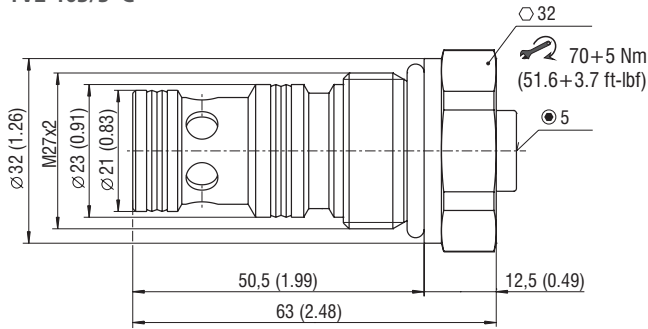

Adapter M10x1/G1/4-ED
 addition of equipment
 for external LS connection
 Ordering number: 19860700

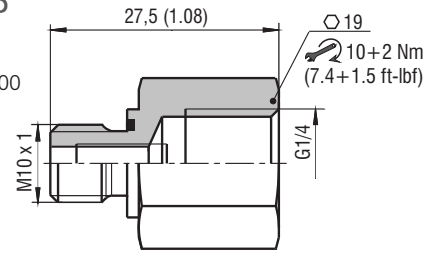

TV2-103/S*S

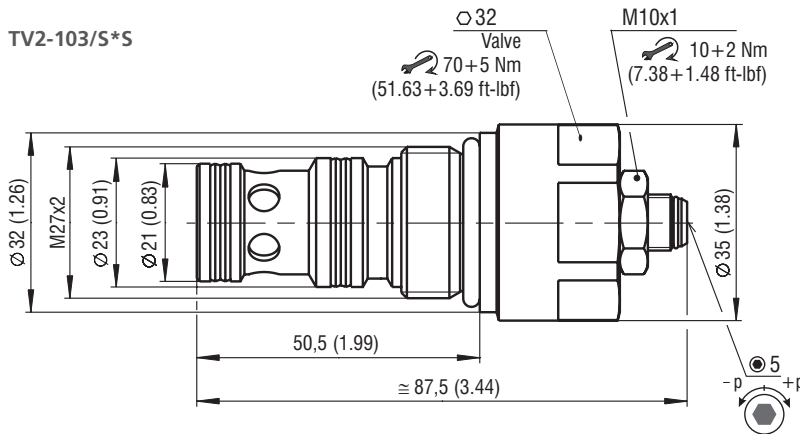

TV2-103/S*RP

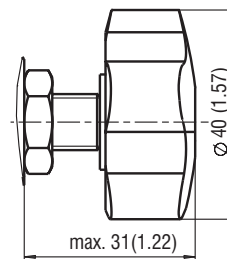

Application Example

Meter-in compensator

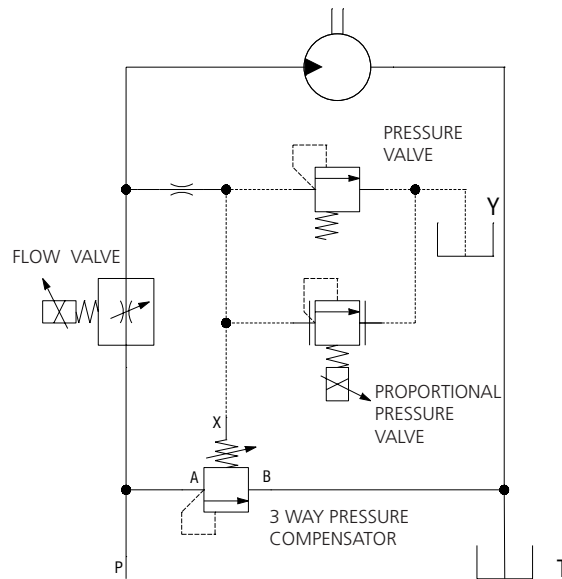

Ordering Code

TV2-103/S					
3-Way pressure compensator, spool-type, direct-acting					
Nominal size M27x2 / QM3					
3-Way pressure compensator					
Cartridge design					
Pressure range 4 - 12 bar (58 - 174 PSI), 10 bar (145 PSI) "C" Model 10 - 14 bar (145 - 203 PSI), 14 bar (203 PSI) "C" Model	1	2			
				A	Surface treatment zinc-coated (ZnCr-3), ISO 9227 (240 h)
				B	zinc-coated (ZnNi), ISO 9227 (520 h)
					Seals NBR FPM (Viton)
				V	No designation
				C	Adjustment option fixed setting, not adjustable
				S	allen key (hex. 5), without protective cap
				RP	hand knob, plastic