

Technical Features

- › Hydraulic safety relief valve suitable for use as a safety device in Category IV Group 2 applications acc.to European Commission (EC) Pressure Equipment Directive (PED) 2014/68/EU
- › CE marked valves are supplied with “Declaration of Conformity”, “Operating Instructions” and the list of residual risks
- › Always follow the operating instructions supplied with the valve!
- › Excellent stability throughout flow range with rapid response to dynamic pressure changes
- › Low hysteresis, accurate pressure control and low pressure drop through CFD optimized flow paths
- › Wide pressure range up to 420 bar
- › Hardened precision parts
- › Sharp-edged steel seats for dirt-tolerant performance
- › Leak-free closing and suitable for fast cycling with long life
- › In the standard version, the valve is zinc-coated for 240 h protection acc. to ISO 9227

Functional Description

A poppet type, direct acting hydraulic relief valve in the form of a screw-in cartridge intended for use as a pressure limiting device for common hydraulic circuit protection. The spring acts on the poppet and presses it onto the valve seat. If the hydraulic pressure is below the pre-set value, the valve is closed. If the hydraulic force exceeds the pre-set value the valve opens and flow passes to tank port until the system pressure falls below the spring pre-set value and the valve closes back again.

Technical Data

Valve size / Cartridge cavity		7/8-14 UNF-2A / B2 (C-10-2)
Max. flow	l/min (GPM)	60 (15.9)
Max. operating pressure	bar (PSI)	420 (6090)
Max. pressure (T port)	bar (PSI)	250 (3630)
Fluid temperature range (NBR)	°C (°F)	-30 ... +100 (-22 ... 212)
Fluid temperature range (FPM)	°C (°F)	-20 ... +120 (-4 ... 248)
Max. leakage of closed valve at 80 % cracking pressure	cm ³ /min	0.1
Viscosity range	mm ² /s (SUS)	10 ... 500 (49 ... 2450)
Weight	kg (lbs)	0.27 (0.60)
Datasheet		Type
General information		GI_0060
Products operating conditions		
Valve bodies	In-line mounted	SB_0018
	Sandwich mounted	SB-04(06)_0028
Cavity details / Form tools	SMT_0019	SB-*B2*
Spare parts	SP_8010	SMT-B2*

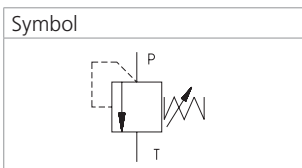

Characteristics measured at v = 32 mm²/s (156 SUS)

Relief pressure related to flow rate

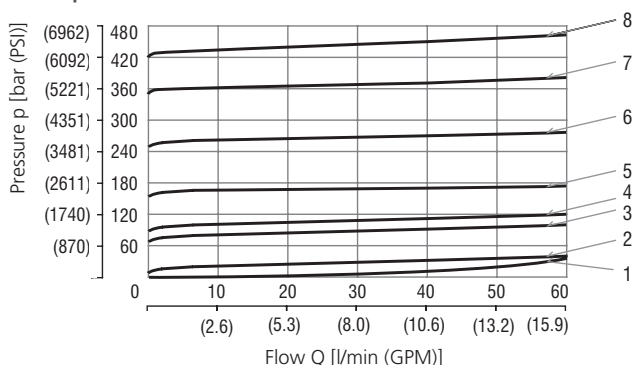

	Pressure range
8	42
7	35
6	25
5	16
4	10
3	6
2	2
1	Min. pressure setting

Valves Adjusted by the Manufacturer

- › The valves are adjusted for the specified pressure at the relevant flow rate and they are fitted with tamper-indicating seals
- › The pressure and flow rate values are indicated in the valve description on the product [pressure: in bar, flow rate in l/min]
- › The seals bear the company logo

Valves NOT Adjusted by the Manufacturer

- › Valves have no tamper-indicating seals
- › No pressure and no flow rate indicated - SR1A-B2/Hxxx-CE1017
- › After the completion of the functional test, the adjusting screw is completely loosened and the pressure is set to $p = 0$ bar
- › To adjust the required valve pressure proceed as follows:
 - turn the adjusting screw to the right (clockwise) to increase the pressure
 - turn the adjusting screw to the left (counter-clockwise) to decrease the pressure
- › The manufacturer accepts no responsibility for the adjustment, securing, and sealing of the valve

Residual Risks

Residual risks are listed and preventive measures against the occurrence of residual risk are described in the document „Operating instructions for pressure relief valve SR1A-B2/Hxxx-CE1017“ which is delivered with each valve.

Operating Region

The diagram shows the operating region where the valve meets the requirements of Directive 2014/68/EU and Standard ISO 4126-1 on maximum short-time overshoot of system pressure by 10 % above the set cracking pressure when the valve opens.

The dynamics of the valve depend on the kinematic viscosity of working fluid.

Measurement conditions: oil Renolin VG 32, $T = 40$ °C (104 °F), $V = 0.5$ l (0.132 gal US)

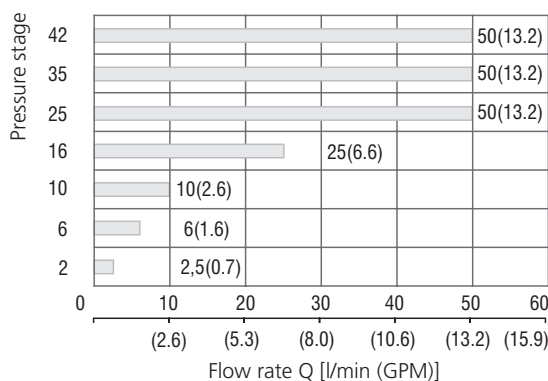

Operating region characteristics from certification of SR1A-B2/Hxxx-CE1017*

Dimensions in millimeters (inches)

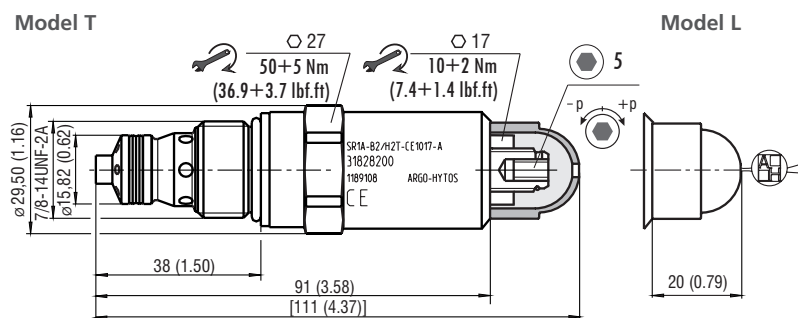

Ordering Code

SR1A-B2 / H [] [] [] - CE1017- [] - []		
Pressure relief valve, PED certified, poppet type, direct acting		
Valve cavity 7/8-14 UNF (C-10-2)		
Model High performance		
Pressure range		
up to 25 bar (360 PSI)	2	
up to 63 bar (910 PSI)	6	
up to 100 bar (1450 PSI)	10	
up to 160 bar (2320 PSI)	16	
up to 250 bar (3630 PSI)	25	
up to 350 bar (5080 PSI)	35	
up to 420 bar (6090 PSI)	42	
Surface treatment		
A		zinc-coated (ZnCr-3), ISO 9227 (240 h)
B		zinc-coated (ZnNi), ISO 9227 (520 h)
Relief pressure and flow rate setting		
120/5.8		120 bar / 5.8 l/min
Certification PED		
		notified body number CE1017
Seals		
NBR		
FPM (Viton)		
Adjustment option		
T		allen key (hex. 5), with protective cap
L		allen head (hex. 5), with protective cap, sealable (lockwire holes)
No designation V		

If not preset valves are ordered, pressure and flow rate information is not shown.