

SFD2F-D4/I

1-5/16-12 UN • Q_{max} 150 l/min (40 GPM) • p_{max} 350 bar (5100 PSI)

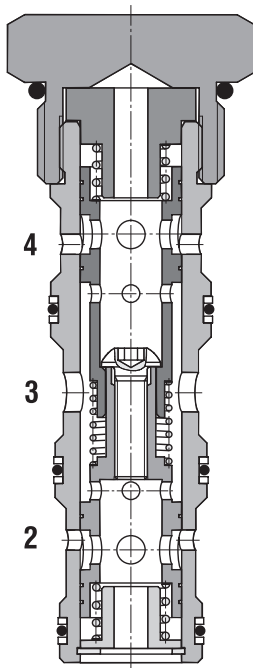

Technical Features

- › Divides pump flow to operate two actuators under different load conditions
- › Re-combines the return flows to synchronize actuator movement
- › Division and combination of flows largely independent of the load
- › Used for synchronisation controls and differential lock
- › High accuracy under load and pressure imbalance
- › High flow capacity
- › Flow variation $\pm 10\%$ with the maximum variation of pressure and inlet flow
- › In the standard version, the valve is zinc-coated for 240 h protection acc. to ISO 9227

Functional Description

The inlet flow passes through the two orifices in the valve housing, then through the spools and out of the radial holes in the sleeve. The matched orifices and compensating springs ensure that the flow is divided equally, excess flow in either direction causes the spool to move and close the radial holes in the sleeve until pressure balance is restored. In the reverse direction the spools shift closer together and regulate the inflow through the radial ports.

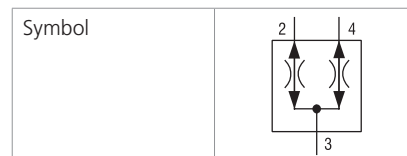

Technical Data

Valve size / Cartridge cavity		1-5/16-12 UN-2A / D4
Max. flow	l/min (GPM)	150 (39.6)
Max. operating pressure	bar (PSI)	350 (5080)
Fluid temperature range (NBR)	°C (°F)	-20 ... +90 (-4 ... +194)
Division ratio	%	50 / 50 standard
Max. flow variation	%	± 10
Weight	kg (lbs)	0.36 (0.79)

		Datasheet	Type
General information		GI_0060	Products and operating conditions
Valve bodies	In-line mounted	SB_0018	SB-D4*
Cavity details		SMT_0019	SMT-D4*
Spare parts		SP_8010	

Characteristics measured at $v = 40 \text{ mm}^2/\text{s}$ (195 SUS)

Pressure drop related to inlet flow rate

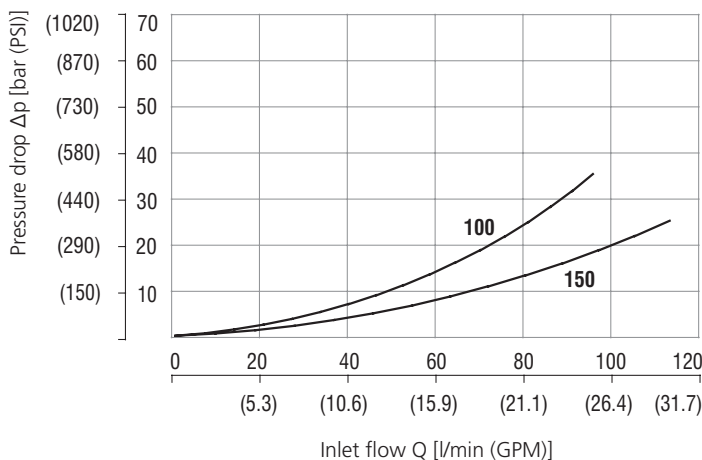

Notice: When used in cylinders select the size to suite the return flow rate. Blocking one leg will result in a large reduction in flow from the other. Valves with higher working pressures are available. Contact the main office for details.

Dimensions in millimeters (inches)

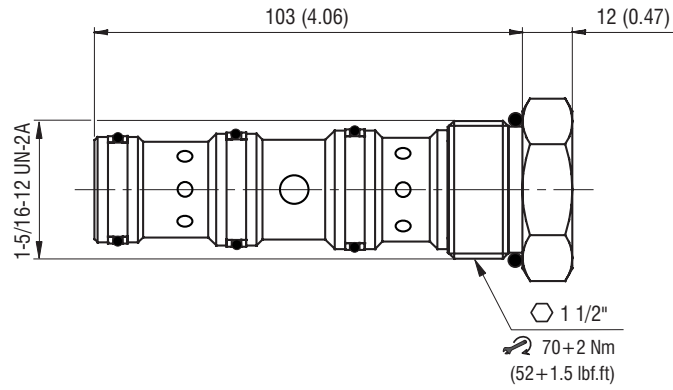

Ordering Code

SFD2F-D4 / I -

Flow divider - combiner valve
1-5/16-12 UNF

Surface treatment
A zinc-coated (ZnCr-3), ISO 9227 (240 h)

Flow rate (inlet flow)
33 - 100 l/min (8.7 - 26.4 GPM) **100**
50 - 150 l/min (13.2 - 39.6 GPM) **150**

No designation
V **Seals**
NBR
FPM (Viton)