

Off-line Filter Unit

# FNAPC1 016

With oil condition monitoring · Nominal flow rate up to 16 l/min / 4.2 gpm · Operating pressure up to 4 bar / 58 psi

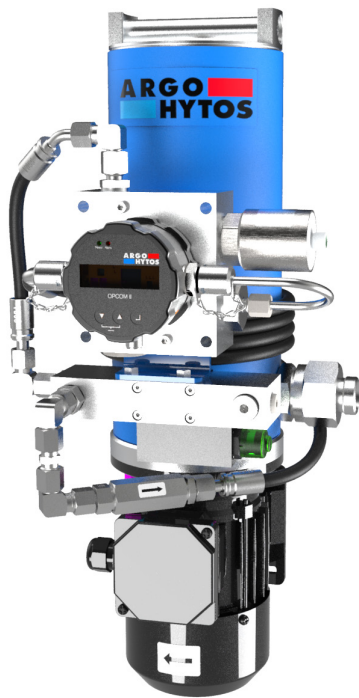

Off-line Filter Unit FNAPC1 016



OPCom Particle Monitor

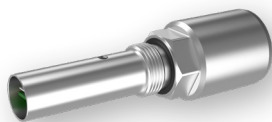

LubCos Humidity / Oil Condition Sensor

## Description

### Application

In the by-pass flow of hydraulic and lubrication systems.

### Performance features

*Protection against wear:*

The EXAPOR®MAX 2 ultra-fine element meets the highest cleanliness standards, even at full flow. A high separation efficiency and excellent dirt holding capacity guarantee maximum protection of the machine and make the FNAPC 1 016 an economical choice for our customers.

*Filtration with oil condition monitoring:*

In addition to efficient filtration, the FNAPC 1 016 provides continuous oil condition monitoring. This functionality significantly increases the reliability and productivity of the hydraulic system.

The unit can be equipped with one or two sensors:

The OPCom particle sensor permanently monitors the current oil cleanliness class.

The second sensor can be supplied in two versions.

The humidity sensor LubCos H<sub>2</sub>O measures the temperature and the relative humidity of the oil.

In the version with LubCos H<sub>2</sub>O+ II, the relative humidity, temperature, permittivity and conductivity are issued. This sensor is prepared for continuous determination of the oil condition. Thereby damages can be detected early or avoided completely.

This offers the opportunity to prevent machine failures and to extend maintenance and oil change intervals.

### Special design features

*Housing cover:*

The ergonomic design of the cover facilitates the opening.

*Compact:*

The filter housing, the internal gear pump and the electric motor are screwed together to form one unit. Apart from the connecting lines to the sensor block and the suction/pressure hose, no pipes are needed.

*Dirt retention valve:*

At the bottom of the filter element, flow through from the inside to the outside, there is a dirt retention valve. This closes while pulling the filter element, which is hung up at the cover, out of the housing. Sedimented dirt is removed together with the filter element. Because of the cover design, the filter element change can be carried out almost without losing any oil.

### Filter elements

Flow direction from the inside to the outside. The star-shaped pleating of the filter material results in:

- › large filter surfaces
- › low pressure drop
- › high dirt-holding capacities
- › particularly long maintenance intervals

### Materials

Pump housing: Aluminum alloy  
Filter housing: Aluminum alloy, painted RAL 5015  
Cover: Aluminum alloy  
Seals: NBR (FPM on request)  
Filter media: EXAPOR®MAX 2 - inorganic, multi-layer microfiber web  
EXAPOR®AQUA - combination of water absorbing filter layers and inorganic, multi-layer microfiber web

### Remarks

Other colors of the filter housing are available on request.

### Accessories

Electrical and / or optical clogging indicators may be ordered together with the off-line filter unit. For choosing the proper clogging indicator see table "Clogging Indicator" in the Ordering Code.

A separate ordering of the clogging indicator is possible. For dimensions and technical data of the clogging indicator, please refer to catalog sheets 60.20 and 60.30.

## Characteristics

### Nominal flow rate

Up to 16 l/min at  $v = 35 \text{ mm}^2/\text{s}$  /  
up to 4.2 gpm at  $v = 162 \text{ SUS}$

### Connection

see Dimensions - drawing

### Filter fineness

3  $\mu\text{m(c)}$  ... 10  $\mu\text{m(c)}$  with EXAPOR®MAX 2  
separating solid particles  
3  $\mu\text{m(c)}$  ...7  $\mu\text{m(c)}$  with EXAPOR®AQUA  
separating water and solid particles

### Dirt-holding capacity

The dirt-holding capacity values in grams from the ISO MTD test dust are in accordance with the ISO 16889 requirements (see Ordering Code, table Filter Element).

### Hydraulic fluids

Mineral oil and biodegradable fluids  
(HEES and HETG, see info-sheet 00.20)

### Temperature range of fluids

0 °C ... +65 °C / +32 °F ... +149 °F  
(also see viscosity range)

### Ambient temperature range

0 °C ... +50 °C / +32 °F ... +122 °F

### Viscosity range\*

Continuous operation min.	For cleanlines monitoring max.	Continuous operation max.	Short-term operation max.
15 $\text{mm}^2/\text{s}$ / 70 SUS	150 $\text{mm}^2/\text{s}$ / 695 SUS	250 $\text{mm}^2/\text{s}$ / 1160 SUS	400 $\text{mm}^2/\text{s}$ / 1860 SUS

\* The maximum continuous viscosity for the filter unit itself is 250  $\text{mm}^2/\text{s}$  / 1160 SUS; an exact measurement of the oil cleanliness class is possible within a viscosity range from 15  $\text{mm}^2/\text{s}$  / 70 SUS to 150  $\text{mm}^2/\text{s}$  / 695 SUS.

### Maximum suction height

1 m / 3.3 ft - first use / unfilled  
6 m / 20 ft - in operating conditions

### Operating pressure

Max. 4 bar / 58 psi,  
pressure protection with pressure relief valve

### Operating position

Vertical, electric motor at the bottom

### Recommended tank capacities

Up to 1500 l  
For units dedicated for bigger tank capacities see catalog sheet FNAPC 045 No. 8051.

## Ordering Code

FNAPC1 016 / - -

Type of filter unit	Code
Off-line filter unit with OPCom particle monitor*	FNAPC1

Nominal flow rate	Code
16 l/min / 4.2 gpm**	016

Filter element				Spare filter element code	Code
	Fineness ( $\beta=200$ ) Dirt-holding capacity for nom. flow 16 l/min / 4.2 gpm		Water capacity		
EXAPOR®MAX 2	3 $\mu\text{m}$	280 g	-	V7.1220-113	V003
EXAPOR®MAX 2	5 $\mu\text{m}$	270 g	-	V7.1220-13	V005
EXAPOR®MAX 3	10 $\mu\text{m}$	210 g	-	V7.1220-06	V010
EXAPOR®AQUA	7 $\mu\text{m}$	38 g	190 ml	Y7.1220-05	Y007
EXAPOR®AQUA	3 $\mu\text{m}$	25 g	205 ml	Y7.1220-113	Y003

Electric motor					Code
Phase(s), voltage	Frequency	Power	Rated current	Electrical connection	
3~400/460 VAC	50/60 Hz	0.45 kW**	2.25/1.30 A T/Y	1	40050
1~230 VAC	50/60 Hz	0.45 kW**	2.8 A	2	23050
1~110 VAC	50/60 Hz	0.45 kW**	5.9 A	2	11050
24 VDC	-	0.3 kW	15.6 A	3	02400

Clogging indicator					Code
Type		Code of indicator	Connection	Datasheet number	
Differential pressure clogging indicator	optical	DG 042-01	Flange	60.30	OD
	electrical	DG 041-32	Flange	60.30	ED
	electrical+optical	DG 041-32 DG 041.1200	Flange	60.30	EOD

Oil condition sensor			Code
Measured parameter	Code of sensor	Datasheet number	
Relative humidity Temperature	LubCos H <sub>2</sub> O	100.00	H
Relative humidity Temperature Relative dielectric number Conductivity	LubCos H <sub>2</sub> O+ II	100.05	HC
Without oil condition sensor			X

Type of monitoring	Hydraulic symbol	Code
Upstream (before filter)	1	
Downstream (after filter)	2	D

\* The OPCom particle monitor is factory fitted in each version of the filter unit. If necessary, the customer can additionally encode the condition sensor.  
\*\* Indications at 50 Hz. At 60 Hz, the value increases by approx. 20 %.

### Order example:

**FNAPC1 016V005/40050-OD-H** off-line filter unit with OPCom particle monitor, 5  $\mu\text{m}$  filter element, 3~phase electric motor, optical differential pressure clogging indicator, humidity sensor LubCos H<sub>2</sub>O. Monitoring type: before filter.

### Remarks:

Combinations listed in this ordering code are standard units. If modifications are required, we kindly ask for your request.

## Dimensions

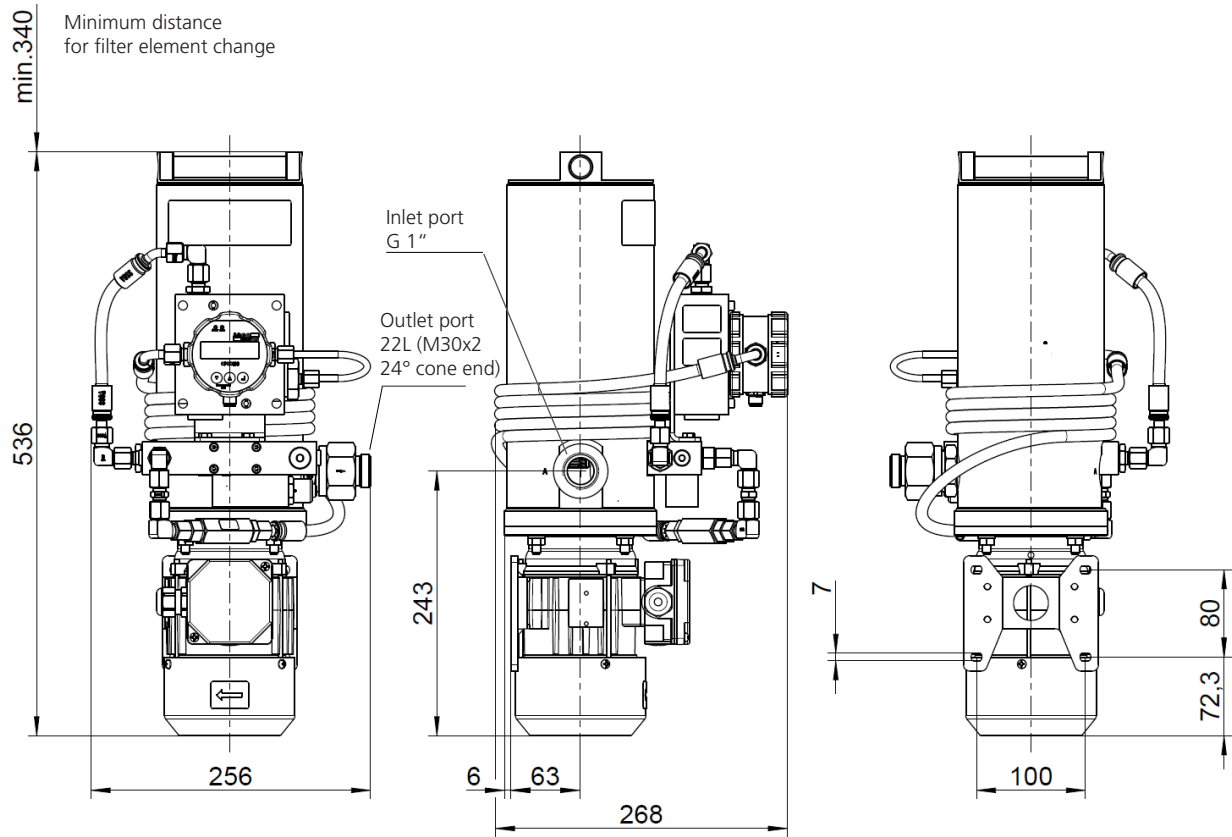

Weight approx. 17 kg / 37.5 lbs

## Hydraulic symbols

1 - Measurement before filter

2 - Measurement after filter

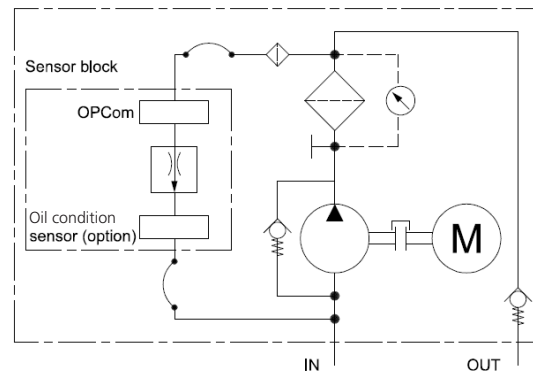
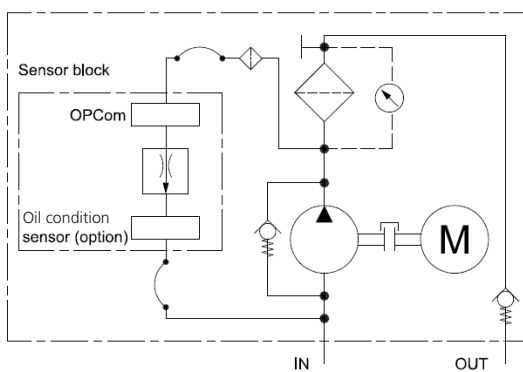

## Electric connections

1

400/460 VAC, 3~phase motor

Delta connection

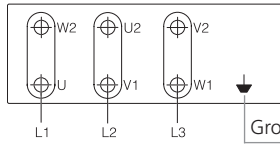

△ Delta Connection

Star connection

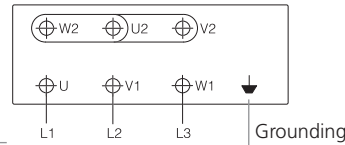

Y Star Connection

2

230 VAC,  
110 VAC, 1~phase motor

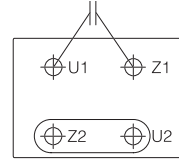

3

24 V, DC motor

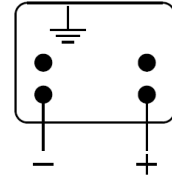

## Quality Assurance

### Quality management according to DIN EN ISO 9001

To ensure constant quality in production and operation, ARGO-HYTOS filter elements undergo strict controls and tests according to the following ISO standards:

- ISO 2941 Verification of collapse / burst pressure rating
- ISO 2942 Verification of fabrication integrity (Bubble Point Test)
- ISO 2943 Verification of material compatibility with fluids
- ISO 3968 Evaluation of pressure drop versus flow characteristics
- ISO 16889 Multi-Pass-Test (evaluation of filter fineness and dirt-holding capacity)
- ISO 23181 Determination of resistance to flow fatigue using high viscosity fluid

**Various quality controls during the production process guarantee the leak-free function and solidity of our filters.**

Illustrations may sometimes differ from the original. ARGO-HYTOS is not responsible for any unintentional mistake in this specification sheet.