

**Return-Suction Filters****E 068 · E 088**In-line mounting · Connection up to G $\frac{3}{4}$  · Nominal flow rate up to 100 l/min**M**

Return-Suction Filter E 088

**Description****Application**

For operation in units with hydrostatic drives, when the return flow is under all operating conditions higher than the oil flow of the feed pump.

**Performance features***Protection against wear:*

By means of filter elements that, in full-flow filtration, meet even the highest demands regarding cleanliness classes.

*Suction filter function:*

Because of the 100 %-filtration of the suction flow, no dirt can get into the feed pump.

*Return filter function:*

By means of full-flow filtration in the system return, the pumps above all are protected from dirt particles remaining in the system after assembly, repairs, or which are generated by wear or enter the system from outside.

### Function (normal operation):

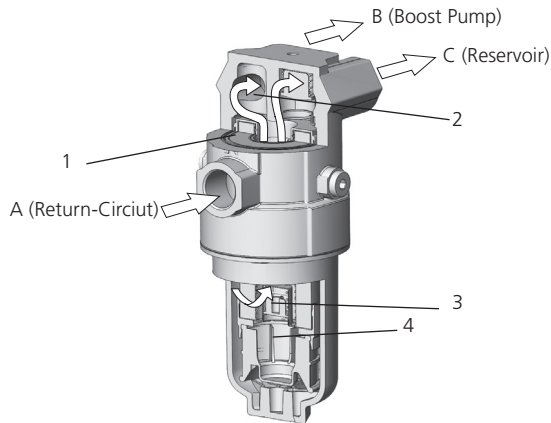

### Function with response of the bypass valve (3):

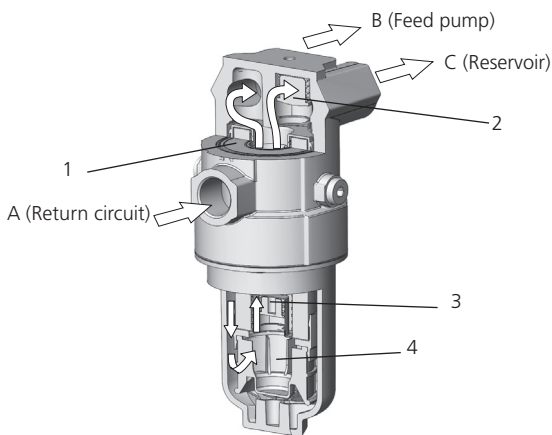

### Functional characteristics

The hydraulic oil returning from the circuit (A) passes the filter element (1), is pressurized by a 0,5 bar check valve (2) and supplied to the feed pump (B). The surplus oil flows filtered over the integral check valve into the reservoir (C).

As the feed pump is always fed with pressurized oil, the risk of cavitation is minimized and full performance is available even during the critical cold start phase.

An integral bypass valve (3) in the filter element (1) prevents too high back pressure (cold start, element contaminates).

A bypass valve with a 125 µm protection strainer (4) guarantees that only filtered oil can get into the feed pump.

### Start up/Deaeration

Deaerating instructions published by the manufacturers of hydraulic drives must be observed.

### Filter elements

Flow direction from outside to the center. The star-shaped pleating of the filter material results in:

- › large filter surfaces
- › low pressure drop
- › high dirt-holding capacities
- › long service life

### Filter maintenance

By using a clogging indicator the correct moment for maintenance is indicated and guarantees therefore the optimum utilization of the filter elements.

In case of maintenance the filter bowl is removed together with the filter element – therefore dirt particles are not flushed back into the tank.

### Accessories

Electrical and optical clogging indicators are available. Dimensions and technical data see catalogue sheet 60.20

**General**

In machines with a hydrostatic drive and combined working hydraulic system, return-suction filters replace the suction or pressure filters previously required for the feed pump of the closed-loop hydrostatic drive circuit as well as the return filter for the open-loop working hydraulic circuit.

While each circuit operates independently with separate filters, the combination of the two circuits via the return-suction filter causes interaction between the circuits.

If the design criteria described below are taken into account, you can take full advantage of the benefits provided by the return-suction filter concept, thus making sure that your system performs reliably even under extreme operating conditions.

**Required return flow in the system**

In order to maintain a precharging pressure of approx. 0,5 bar at the intake of the feed pump, the return flow must exceed the suction flow under any operating condition.

**Permitted feed pump flow rate**

- › at operating temperature ( $v < 60 \text{ mm}^2/\text{s}$ , rpm=max):  
feed pump flow rate  $< 0,8 \times$  rated return flow according to column 2 of selection table
- › at cold start-up ( $v < 1000 \text{ mm}^2/\text{s}$ , rpm = 1000 min<sup>-1</sup>):  
feed pump flow rate  $< 0,8 \times$  rated return flow

Please contact us if your system operates with higher flow rates than stated above.

**Flow velocity in the connecting lines**

- › Flow velocity in the return lines  $\leq 4,5 \text{ m/s}$
- › Flow velocity in the suction lines  $\leq 1,5 \text{ m/s}$

**Permitted pressure in the suction lines**

At cold start up ( $v < 1000 \text{ mm}^2/\text{s}$ , rpm = 1000 min<sup>-1</sup>):  
feed pump flow rate  $< 0,8 \times$  rated return flow. The pressure loss in the suction lines must not exceed 0,4 bar.

**Backpressures in system return lines**

If drain oil from the hydrostatic drive is routed across the filter in addition to the flow of the open-loop circuit, the following has to be observed in order to protect the shaft seals:

- › permitted leakage oil pressure for a given viscosity and speed (manufacturer's specifications!)
- › pressure loss caused by the leakage oil pipes
- › pressure loss caused by the oil cooler used
- › backpressure of the filter for a given flow rate or kinematic viscosity (refer to pressure loss diagrams)

Depending on the application, the use of a cooler bypass valve is recommended.

Generously sized drain oil pipes are also of advantage.

**Filter fineness grades**

With the filter fineness grades available, the following oil cleanliness according to ISO 4406 can be achieved:

- › 10EX2: 18/15/11 ... 14/11/7
- › 16EX2: 20/17/12 ... 17/14/10

Even with the 16EX2 filter fineness grade, the requirements specified by manufacturers of hydrostatic drives are sometimes exceeded significantly. If components requiring a still better oil purity are used, we recommend the 10EX2 filter fineness grade.

**Suggested circuit layouts**

A) The leakage oil of the hydrostatic drive is routed across the filter.

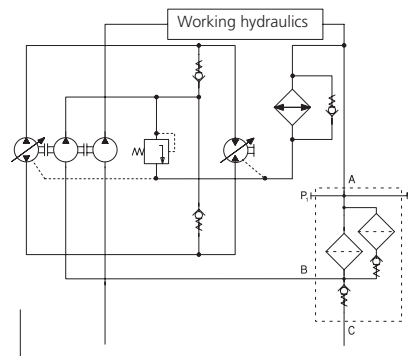

The entire dirt produced in the hydrostatic drive by abrasion is filtered out immediately and is thus not taken in by the pump of the open-loop circuit.

This circuit layout is always recommended if the return flow only slightly exceeds the suction flow, i.e. if there is a risk that the 0,5 bar precharging pressure cannot be maintained.

B) The drain oil of the hydrostatic drive is not routed across the filter but is discharged directly into the tank.

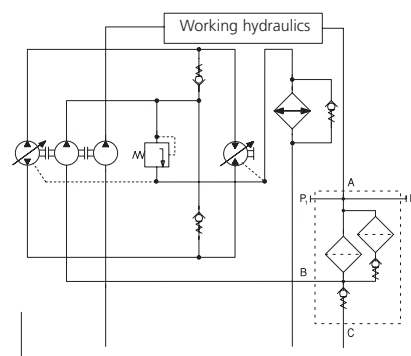

This circuit layout has the advantage that drain oil pressures are comparatively low.

### Nominal flow rate

Up to 100 l/min in return line (see Selection Chart, column 2)

Up to 80 l/min feed pump flow rate (see Layout)

The nominal flow rates indicated by ARGO-HYTOS are based on the following features:

- › closed by-pass valve at  $v \leq 200 \text{ mm}^2/\text{s}$
- › element service life > 1000 operating hours at an average fluid contamination of 0,07 g per l/min flow volume
- › flow velocity in the return lines  $\leq 4,5 \text{ m/s}$
- › flow velocity in the suction lines  $\leq 1,5 \text{ m/s}$

### Connection

Threaded ports according to ISO 228 or DIN 13.

Sizes see Selection Chart, column 6 and 7

(other port threads on request)

### Filter fineness

10  $\mu\text{m(c)}$  ... 16  $\mu\text{m(c)}$

$\beta$ -values according to ISO 16889

(see Selection Chart, column 4 and diagram Dx)

### Dirt-holding capacity

Values in g test dust ISO MTD according to ISO 16889

(see Selection Chart, column 5)

### Hydraulic fluids

Mineral oil and biodegradable fluids

(HEES and HETG, see info-service 00.20).

### Temperature range

-30 °C ... +100 °C (temporary -40 °C ... +120 °C)

### Viscosity at nominal flow rate

- › at operating temperature:  $v < 60 \text{ mm}^2/\text{s}$
- › as starting viscosity:  $v_{\text{max}} = 1000 \text{ mm}^2/\text{s}$
- › at initial operation:  
The recommended starting viscosity can be read from the diagram D (pressure drop as a function of the kinematic viscosity) as follows: Find the 70 %  $\Delta p$  of the cracking pressure of the by-pass valve on the vertical axis. Draw a horizontal line so that it intersects the  $\Delta p$  curve at a point. Read this point on the horizontal axis for the viscosity.

### Operating pressure

Max. 10 bar

### Materials

Filter head:

Aluminium alloy

Filter bowl:

Polyamide, GF-reinforced

Seals:

NBR (FPM on request)

Filter media:

EXAPOR®MAX 2 - inorganic multi-layer microfibre web

### Fitting position

Preferably vertical, filter head on top.

**Δp-curves for complete filters in Selection Chart, column 3  
(80% of the nominal flow volume via connection B)**

**D1** Pressure drop as a function of the **flow volume** at  $v = 35 \text{ mm}^2/\text{s}$  (0 = casing empty)

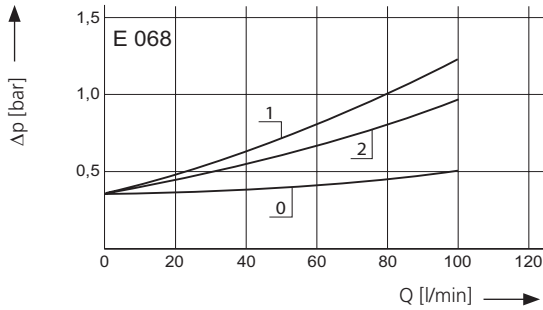

Pressure drop as a function of the **kinematic viscosity** at nominal flow

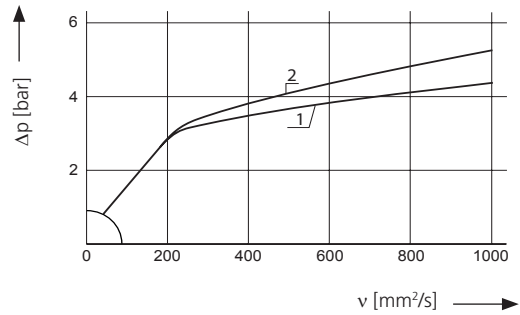

**D2** Pressure drop as a function of the **flow volume** at  $v = 35 \text{ mm}^2/\text{s}$  (0 = casing empty)

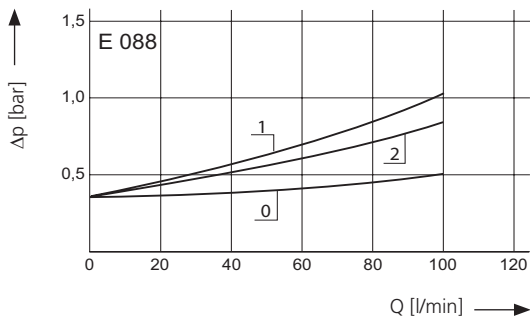

Pressure drop as a function of the **kinematic viscosity** at nominal flow

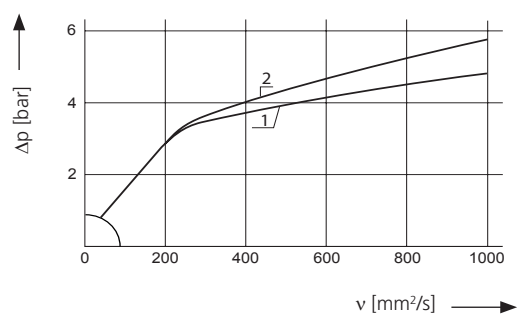

**Filter fineness curves in Selection Chart, column 4**

**Dx** Filtration ratio  $\beta$  as a function of particle size  $x$  obtained by the Multi-Pass-Test according to ISO 16889

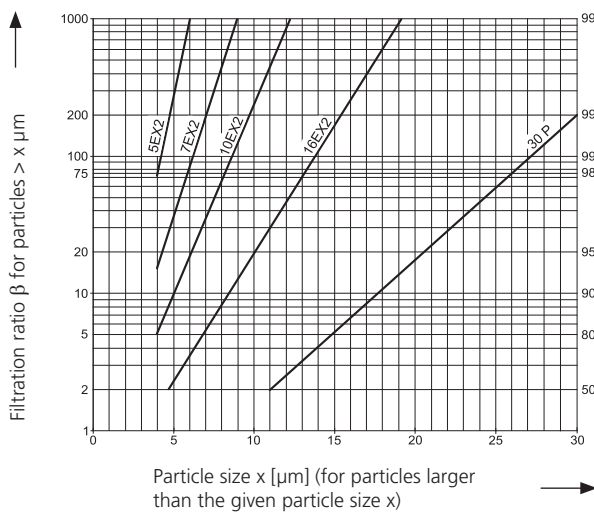

The abbreviations represent the following  $\beta$ -values resp. finenesses:

**For EXAPOR®MAX 2 and Paper elements:**

- 5EX2 =  $\bar{\beta}_{5(c)}$  = 200 EXAPOR®MAX 2
- 7EX2 =  $\bar{\beta}_{7(c)}$  = 200 EXAPOR®MAX 2
- 10EX2 =  $\bar{\beta}_{10(c)}$  = 200 EXAPOR®MAX 2
- 16EX2 =  $\bar{\beta}_{16(c)}$  = 200 EXAPOR®MAX 2
- 30P =  $\bar{\beta}_{30(c)}$  = 200 Paper

Based on the structure of the filter media of the 30P paper elements, deviations from the printed curves are quite probable.

For special applications, finenesses differing from these curves are also available by using special composed filter material.

## Selection Chart

Part No.	Nominal return flow	Pressure drop see diagram <b>D1</b> /curve no.	Filter fineness see Diagr. <b>Dx</b>	Dirt-holding capacity	Connection A	Connection B/C	Cracking Pressure of CV <sup>1</sup>	Cracking Pressure of PRV <sup>2</sup>	Symbol	Replacement filter element Part No.	Weight	Remarks
1	l/min	3	4	g	6	7	bar	bar	10	11	kg	13
E 068-156	50	<b>D1/1</b>	10EX2	15	G $\frac{3}{4}$	G $\frac{3}{4}$	0,5	2,5	1	K3.0718-56	1,3	-
E 068-158	80	<b>D1/2</b>	16EX2	15	G $\frac{3}{4}$	G $\frac{3}{4}$	0,5	2,5	1	K3.0718-58	1,3	-
E 088-156	65	<b>D2/1</b>	10EX2	20	G $\frac{3}{4}$	G $\frac{3}{4}$	0,5	2,5	1	K3.0721-56	1,4	-
E 088-158	100	<b>D2/2</b>	16EX2	20	G $\frac{3}{4}$	G $\frac{3}{4}$	0,5	2,5	1	K3.0721-58	1,4	-

<sup>1</sup> Cracking pressure of check valve

<sup>2</sup> Cracking pressure of pressure relief valve

All filters are delivered with two plugged clogging indicator connections M12 x 1,5. As clogging indicators on the return side (P<sub>1</sub>) either manometers or electrical pressure switches can be used.

**For the appropriate clogging indicators see catalogue sheet 60.20.**

### Remarks:

- › The start of the red area respectively the switching pressure of the electrical pressure switch has always to be lower than the cracking pressure of the pressure relief valve (see Selection Chart, column 9).
- › Clogging indicators are optional and always delivered detached from the filter.
- › The filters listed in this chart are standard filters. If modifications are required, we kindly ask for your request.
- › For deaeration a bleed screw (for connection P<sub>1</sub>) with Part No. SV 0112.15 is available.

## Dimensions

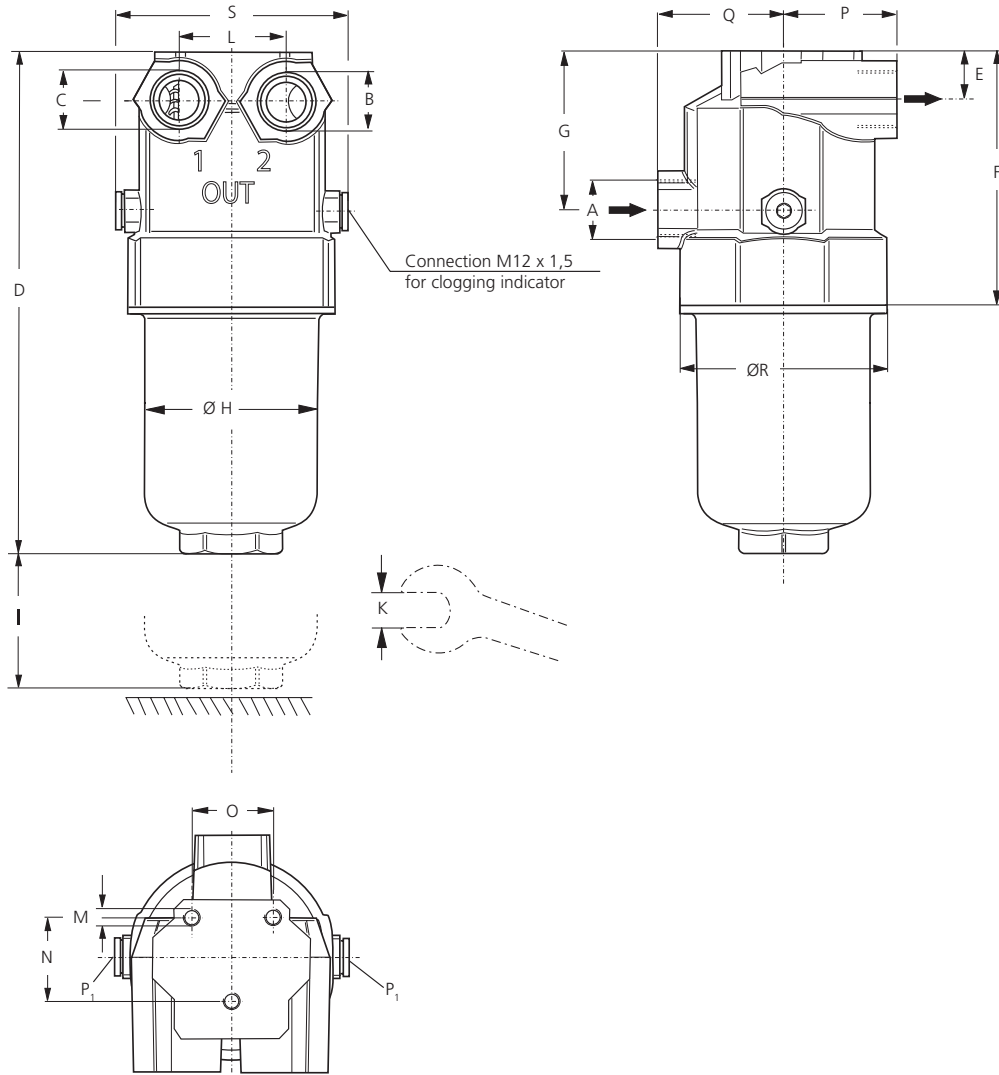

## Measurements

Type	A	B	C	D	E	F	G	H	I	K	L	M Ø / depth	N	O	P	Q	R	S
E 068	G $\frac{3}{4}$	G $\frac{3}{4}$	G $\frac{3}{4}$	234	23,3	119	74,2	80	75	AF41	50	M8/15	40	38,1	53,5	57,5	95	108
E 088	G $\frac{3}{4}$	G $\frac{3}{4}$	G $\frac{3}{4}$	268	23,3	119	74,2	80	75	AF41	50	M8/15	40	38,1	53,5	57,5	95	108

## Symbols

1

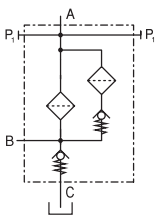

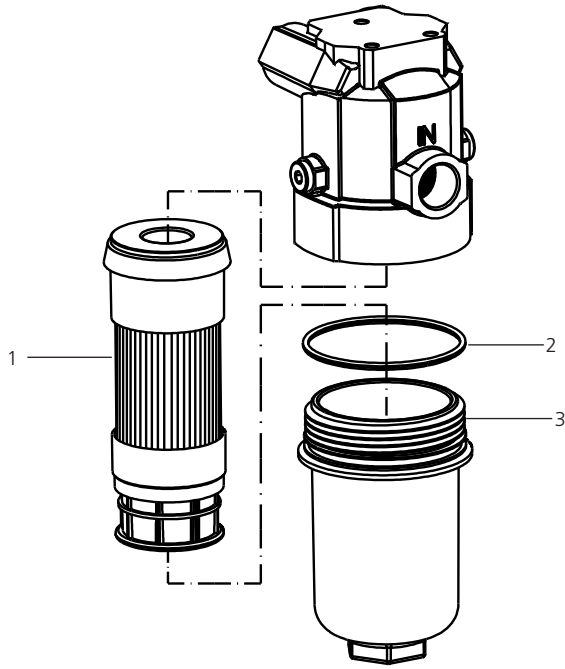

Pos.	Designation	Part No.
1	Filter element	see Chart / col. 11
2	O-ring 82,14 x 3,53	N007.0824
3	Filter bowl E 068	E 068.0101
3	Filter bowl E 088	E 068.0102

The functions of the complete filters as well as the outstanding features of the filter elements assured by ARGO-HYTOS can only be guaranteed if original ARGO-HYTOS spare parts are used.

## Quality Assurance

### Quality management according to DIN EN ISO 9001

To ensure constant quality in production and operation, ARGO-HYTOS filter elements undergo strict controls and tests according to the following ISO standards:

ISO 2941	Verification of collapse/burst pressure rating
ISO 2942	Verification of fabrication integrity (Bubble Point Test)
ISO 2943	Verification of material compatibility with fluids
ISO 3968	Evaluation of pressure drop versus flow characteristics
ISO 16889	Multi-Pass-Test (evaluation of filter fineness and dirt-holding capacity)
ISO 23181	Determination of resistance to flow fatigue using high viscosity fluid

**Various quality controls during the production process guarantee the leakfree function and solidity of our filters.**

Illustrations may sometimes differ from the original. ARGO-HYTOS is not responsible for any unintentional mistake in this specification sheet.